



# Chemical Injection Technologies

## Product/Specification Bulletin

### SUPERIOR™ Gas Detector Model SLD-2 Two Channel (Two Gases)



#### GENERAL DESCRIPTION

The SUPERIOR™ Model SLD-2 Dual Channel Gas Detector is a state-of-the-art, microprocessor controlled instrument capable of detecting Chlorine, Sulfur Dioxide, Ammonia, and Ozone gasses at levels far below the threshold of human awareness. SUPERIOR™ Dual Point Gas Detectors are an “operator friendly” and economical way to protect personnel and property. The detector will individually monitor any two listed gas levels, or two separate locations of the same gas, well below OSHA requirements, and activate warning devices when threshold levels are reached.

The Model SLD-2 Dual Channel Gas Detector consists of a Controller/Alarm module, and two remote gas sensor modules which can each be located up to 1000 feet (305 meters) away from the controller. The sensors respond immediately to the presence of gas, and recover very quickly when the gas has cleared. The controller/alarm module is housed in a NEMA-4X enclosure. Many features which are extra cost options in other gas detectors, are standard with the SLD-2.

#### FEATURES

- User-friendly key pad interface with functions indicated by individual menu display screens.

- 16-character by 2-line display, with green LED back light for easy reading, even in low light areas.
- NEMA-4X controller enclosure.
  - 95 dB internal alarm horn.
  - Event alarm log records up to 256 events, with time and date, which can be viewed on the display or downloaded from the optional serial port.
  - Sensor life and calibration reminder timers.
  - 4-20 mA gas level monitor output.
  - Password protection for all parameter settings.
  - High, Low, Latching and Non-Latching alarm relays.
  - Two level alarm settings for “Warning” and “Danger” gas levels.
  - All alarm relays are user adjustable for N/O, N/C, Latch or Non-Latch.
- Flashing backlight screen when alarm acknowledgment is required.
- Remote alarm acknowledgment of any alarms up to 250 ft. (76 meters) from the controller.
- Individual, real-time display of each monitored gas level.

#### APPLICATION

The SUPERIOR™ Model SLD-2 is designed for use in:

- Wastewater treatment plants
- Water purification plants
- Swimming pools
- Cooling towers - air scrubbers
- Food and beverage processing
- Chemical processing

SUPERIOR™ design provides ease of operation with top performance. The SUPERIOR™ Series SLD-2 Dual Channel Gas Detector can be placed where most convenient for the operator for ease of use while the gas sensor can be placed in the monitored environment up to 1000 feet (305 meters) away.

Materials used in manufacturing the SUPERIOR™ Series SLD-2 Dual Channel Gas Detectors have been carefully selected for their superior quality and performance in situations and conditions far more extreme than conditions to be encountered in actual use.

#### AVAILABLE OPTIONS

- Internal Battery backup with charger. An external UPS may also be used to allow full function operation over extended power outages.
- RS232 serial port for downloading data.

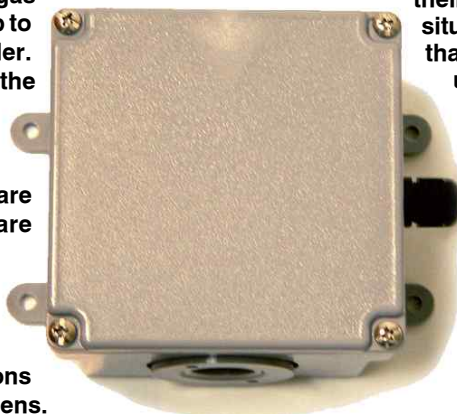

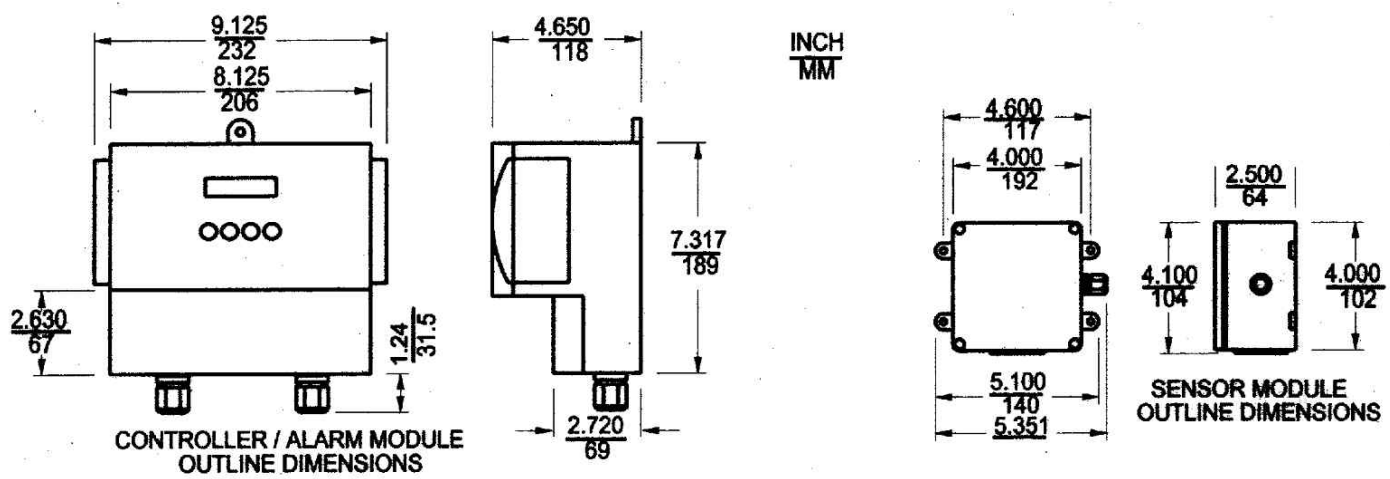

## TECHNICAL SPECIFICATIONS

### Sensor Inputs (Analog Inputs)

Maximum Number of Gas Sensors:	Two
Gas Sensor Signal:	Current Loop ( 4-20- mA )
Loop Voltage:	15V, short circuit protected
Maximum Sensor Distance:	1000 ft. (305 meters)

### Sensor Outputs (Analog Outputs)

Signal Type:	4-20 Ma
Voltage Compliance:	12V
Maximum Load:	600Ω
Minimum Load:	0Ω
Number of Outputs:	Two

### Relays & I/O

Type:	Form-A (N/O)
Maximum Current Rating:	5A ( resistive )
Suppression	275 V, 10J, MOV
Voltage:	250VAC/30VDC
Quantity:	5 ( 2 Danger, 2 Warning, 1 Alarm)

Remote Acknowledgement Switch:	Yes
Horn Output:	Yes:10-24V

### Computer & Display

Microcontroller:	68HC12 type
ROM:	128k, FLASH
ROM Upgradable in Field:	Yes
Real-Time Clock:	Yes
RS232 Port:	2 ( one standard, one optional)
Display:	LCD, 2-Line, 16 char./line, backlit
Pushbuttons:	Four, tactile dome type

### Power Supply

A.C. Line Voltage (115V):	85V - 130V
A.C. Line Voltage (230V):	170V - 250V
Power:	12W
Optional D.C. Supply:	Sealed NiMH

### Environmental

Operating Temperature:	32°F to 122°F (0°C to 50°C)
Humidity:	2%, non-condensing

### ***Chemical Injection Technologies, Inc.***

835 Edwards Rd., Ft. Pierce, FL, 34982, USA

(772) 461-0666 Fax: (772) 460-1847

E-Mail: [superior@chlorinators.com](mailto:superior@chlorinators.com)

[www.chlorinators.com](http://www.chlorinators.com)